

*Harnessing the Sun:*

Photovoltaics, Solar Thermal,  
and Concentrated Solar Power.

Christopher Polashenski, PhD  
21 November 2011

What we will talk about...

- Types of solar energy capture and how they work
  - Photovoltaics (PV)
  - Solar Thermal Collectors
  - Concentrated Solar Power (CSP)
- How to size a system for a project
- (Next week) Scalability to the global climate problem

# Photovoltaics

Converting light into electricity directly.



## How does PV work

- Photovoltaic effect – First recognized in 1839 by French physicist Alexandre-Edmond Becquerel. (not Henri, his dad)
  - Photons hit cell
  - If just the right energy, bump electrons from valence position into a conduction level
  - Electrons in conduction level travel and make electricity...

## How does PV work

- Photovoltaic effect – First recognized in 1839 by French physicist Alexandre-Edmond Becquerel. (not Henri, his dad)
  - Photons hit cell
  - If just the right energy, bump electrons from valence position into a conduction level
  - Electrons in conduction level travel and make electricity...

## BUT WHY?

## A bit about semiconductors...

Periodic Table of the Elements © www.elementsdatabase.com

1 H																	2 He
3 Li	4 Be	■ hydrogen ■ alkali metals ■ alkali earth metals ■ transition metals										5 B	6 C	7 N	8 O	9 F	10 Ne
11 Na	12 Mg	■ poor metals ■ nonmetals ■ noble gases ■ rare earth metals										13 Al	14 Si	15 P	16 S	17 Cl	18 Ar
19 K	20 Ca	21 Sc	22 Ti	23 V	24 Cr	25 Mn	26 Fe	27 Co	28 Ni	29 Cu	30 Zn	31 Ga	32 Ge	33 As	34 Se	35 Br	36 Kr
37 Rb	38 Sr	39 Y	40 Zr	41 Nb	42 Mo	43 Tc	44 Ru	45 Rh	46 Pd	47 Ag	48 Cd	49 In	50 Sn	51 Sb	52 Te	53 I	54 Xe
55 Cs	56 Ba	57 La	72 Hf	73 Ta	74 W	75 Re	76 Os	77 Ir	78 Pt	79 Au	80 Hg	81 Tl	82 Pb	83 Bi	84 Po	85 At	86 Rn
87 Fr	88 Ra	89 Ac	104 Unq	105 Unp	106 Unh	107 Uns	108 Uno	109 Uue	110 Uun								
58 Ce	59 Pr	60 Nd	61 Pm	62 Sm	63 Eu	64 Gd	65 Tb	66 Dy	67 Ho	68 Er	69 Tm	70 Yb	71 Lu				
90 Th	91 Pa	92 U	93 Np	94 Pu	95 Am	96 Cm	97 Bk	98 Cf	99 Es	100 Fm	101 Md	102 No	103 Lr				

# A bit about semiconductors

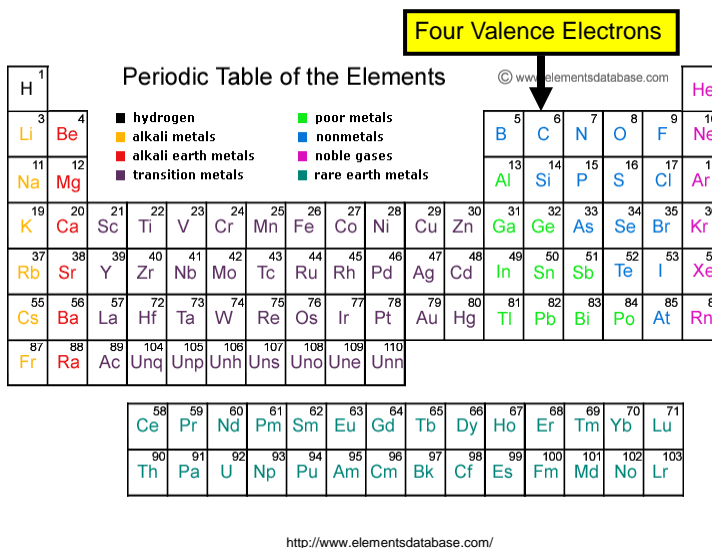

# A bit about semiconductors

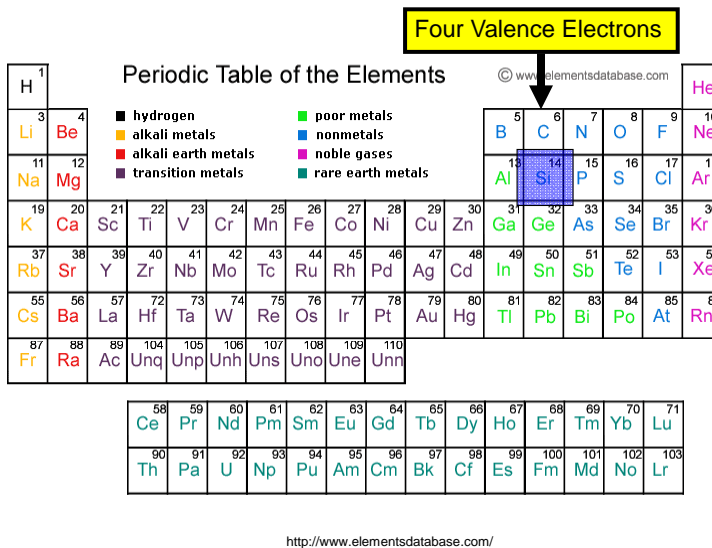

# A bit about semiconductors

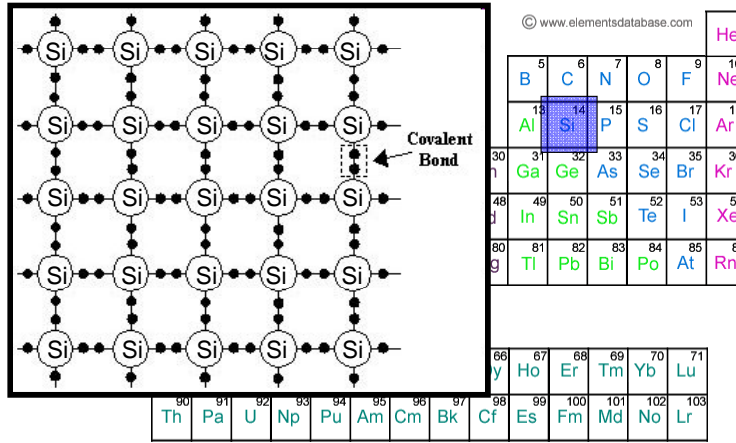

# A bit about semiconductors

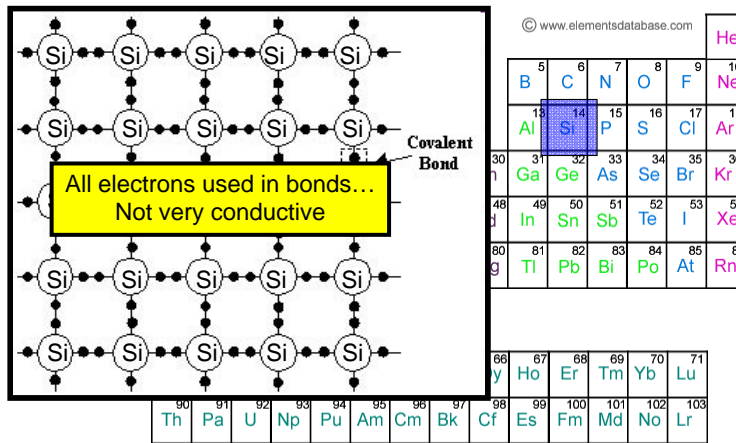

# Doping...

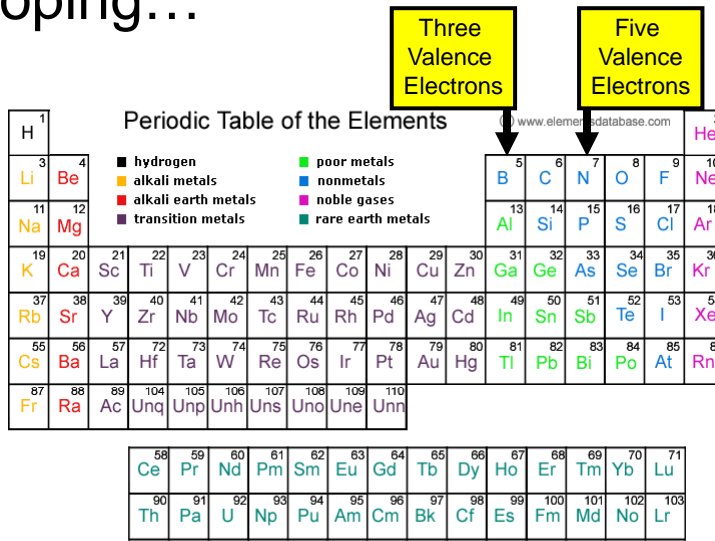

# Doping...

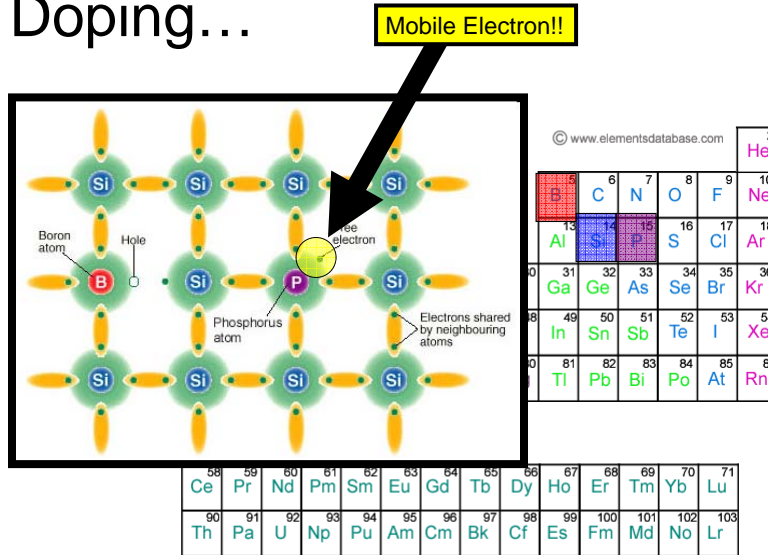



By putting two differently doped semiconductors together, one can make very useful devices...

## Make a P-N Junction

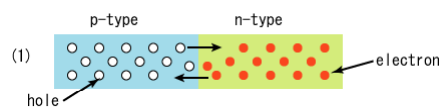

Diffusion Says

Electrons ←

Holes →

<http://upload.wikimedia.org/wikipedia/commons/4/48/PnJunction-PV-E.PNG>

# Make a P-N Junction

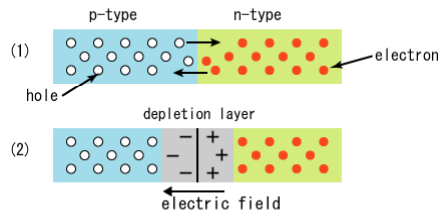

Now:

- Each side started out neutral.
- As you move negative charges left, you create a charge imbalance...
- This creates an electric field and prevents further flow of electrons
- All the electrons and holes in the depletion layer have combined and annihilated... now not conductive

<http://upload.wikimedia.org/wikipedia/commons/4/48/PnJunction-PV-E.PNG>

# Make a P-N Junction

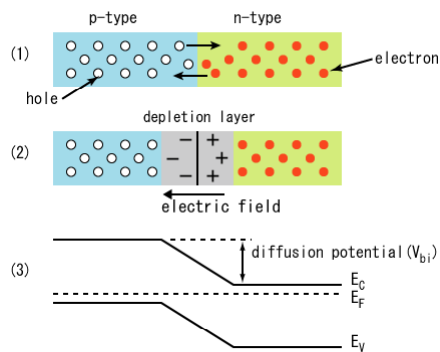

The diffusion creates a voltage across the junction

<http://upload.wikimedia.org/wikipedia/commons/4/48/PnJunction-PV-E.PNG>

# Make a P-N Junction

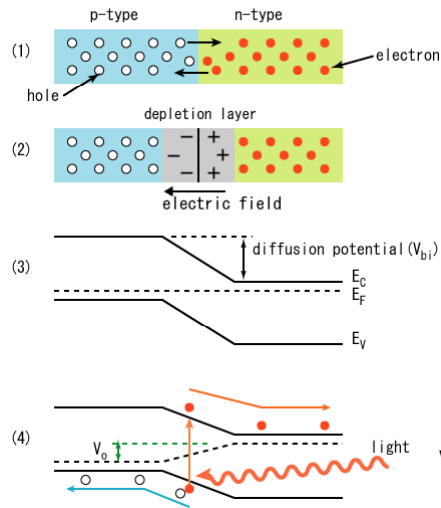

What happens when a photon strikes?

<http://upload.wikimedia.org/wikipedia/commons/4/48/PnJunction-PV-E.PNG>

Electron (may be) excited until it leaves the valence shell, then electric field pushes it to the n type

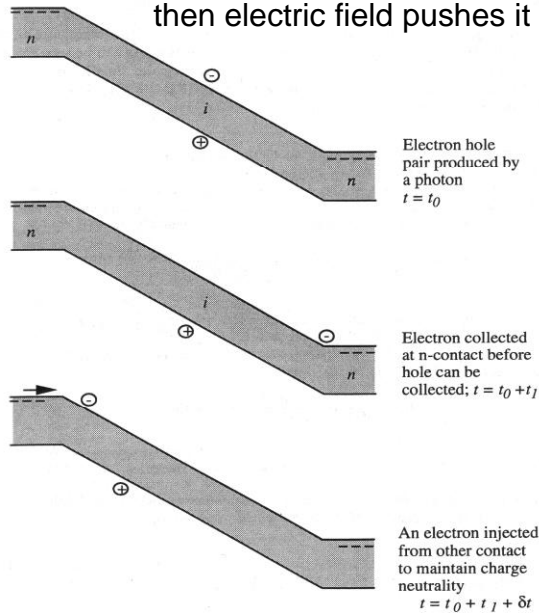

<http://kottan-labs.bgsu.edu/teaching/workshop2001/chapter8.htm>

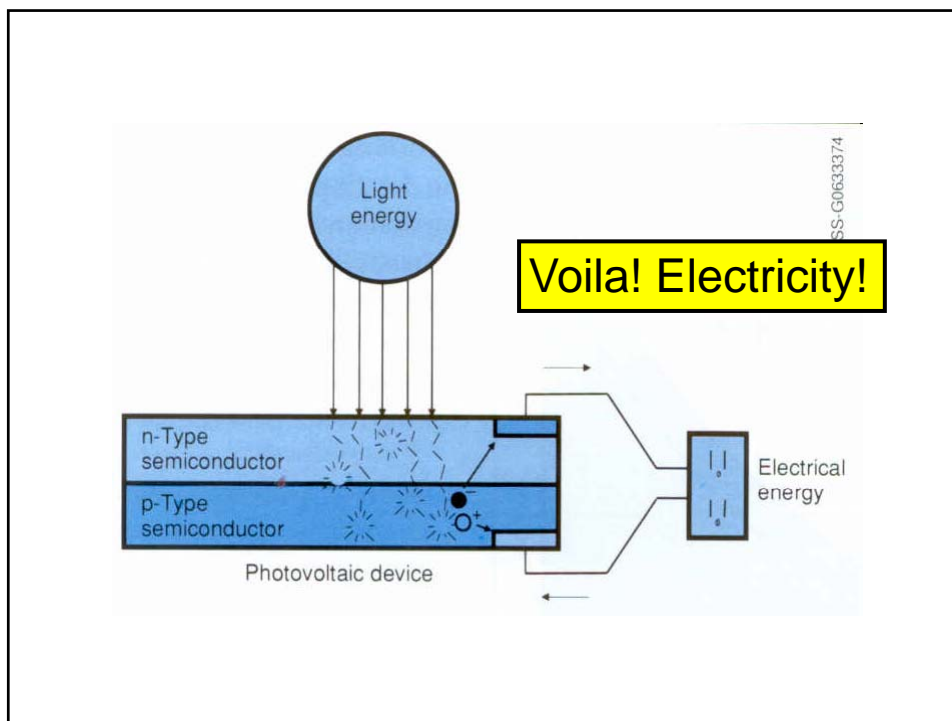

## Solar Thermal Energy

- Heat media (usually water or air)
- Use for space heating or domestic hot water (perhaps industrial processes)

# Flat Plate Collectors

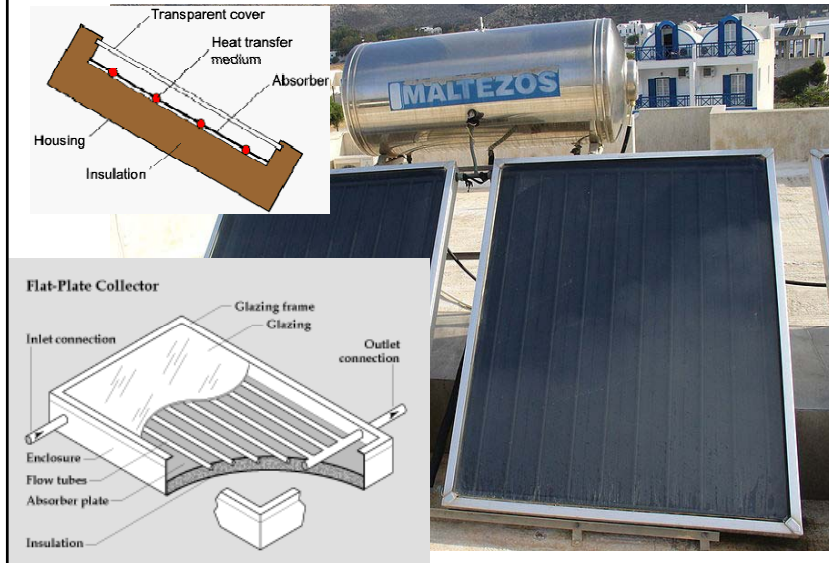

# Evacuated Tube Collectors

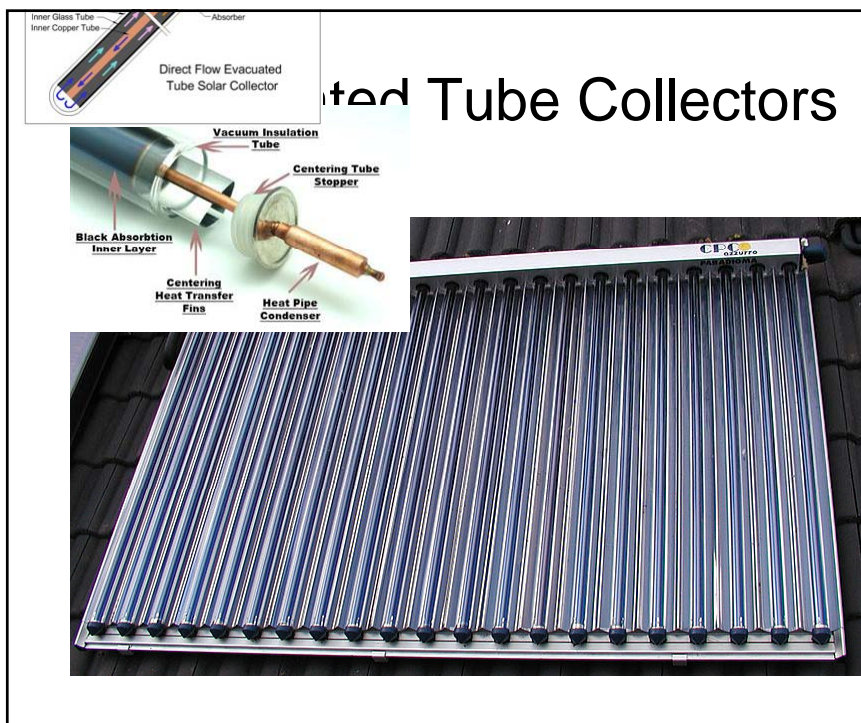

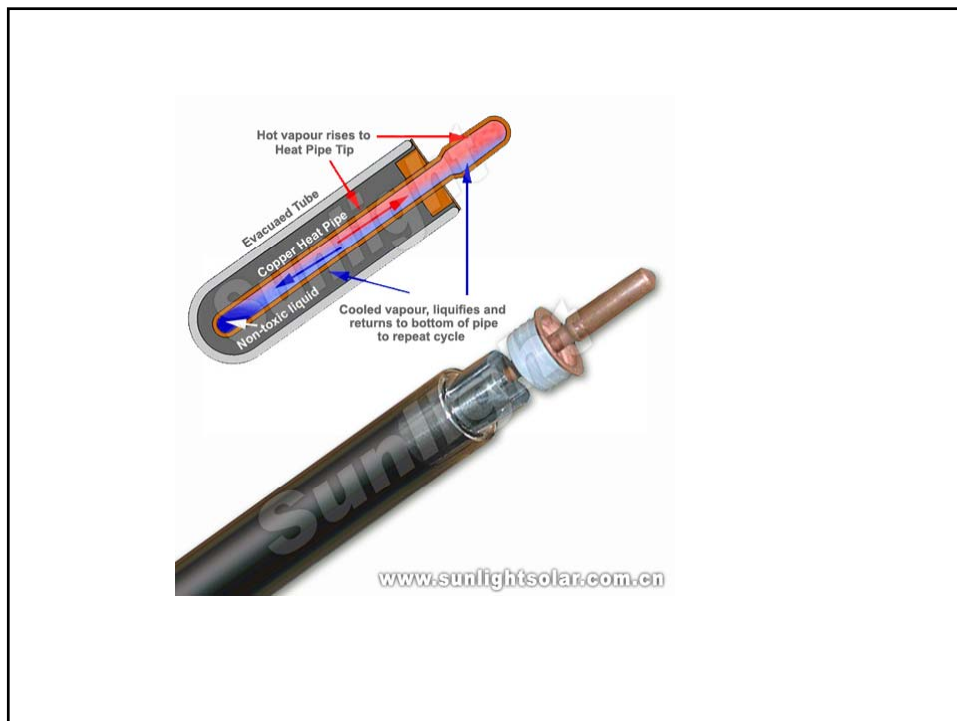
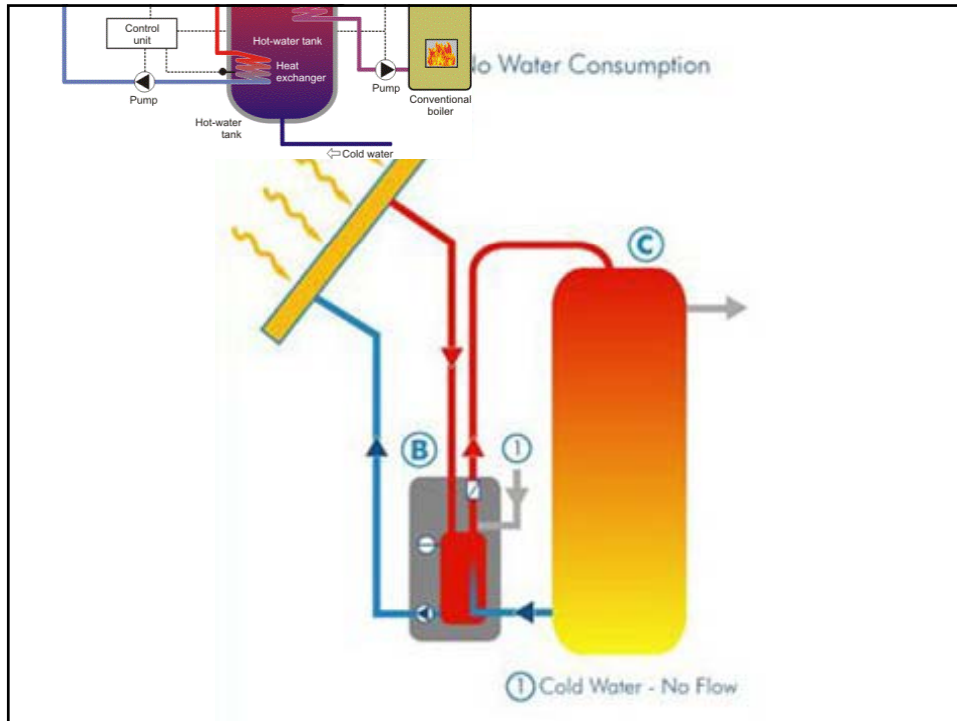

## Parabolic Trough

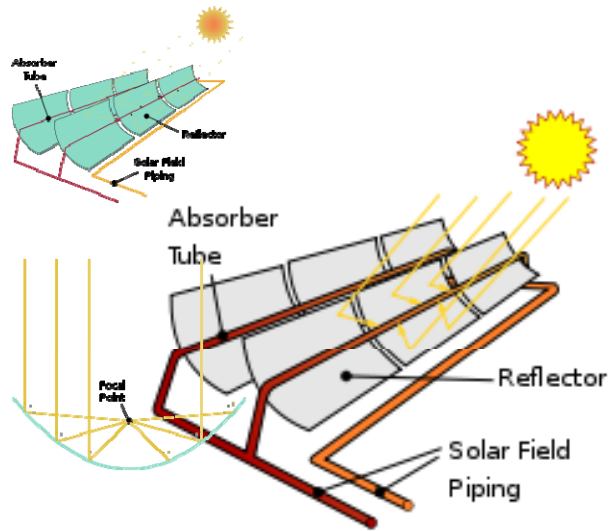

## Concentrated Solar Power



## How do we use this energy?

- AC/DC and inverters
- Battery vs. grid

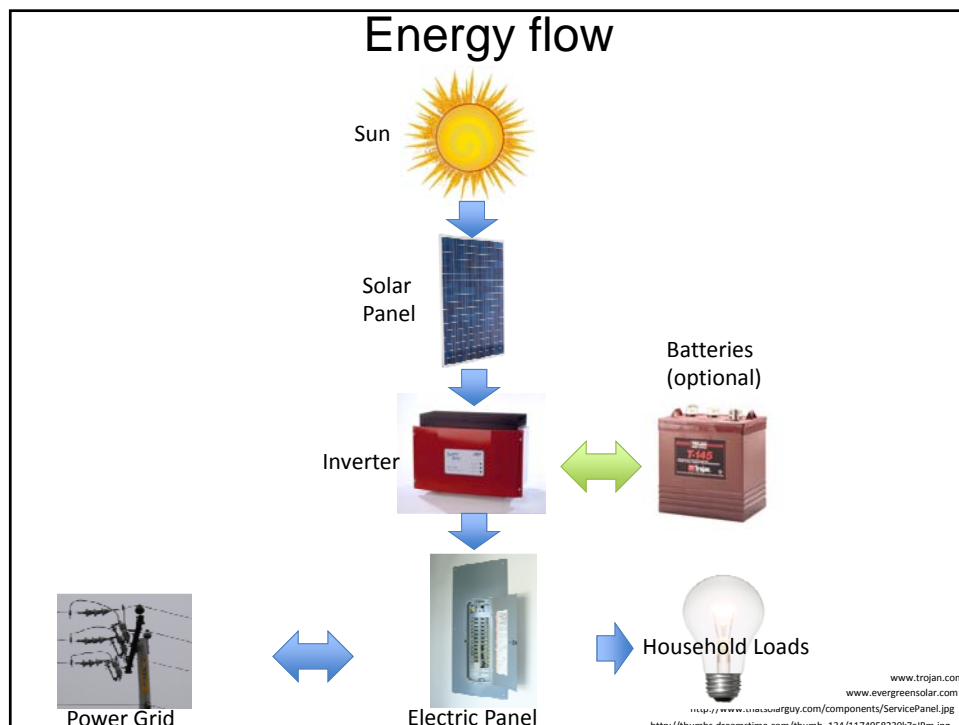

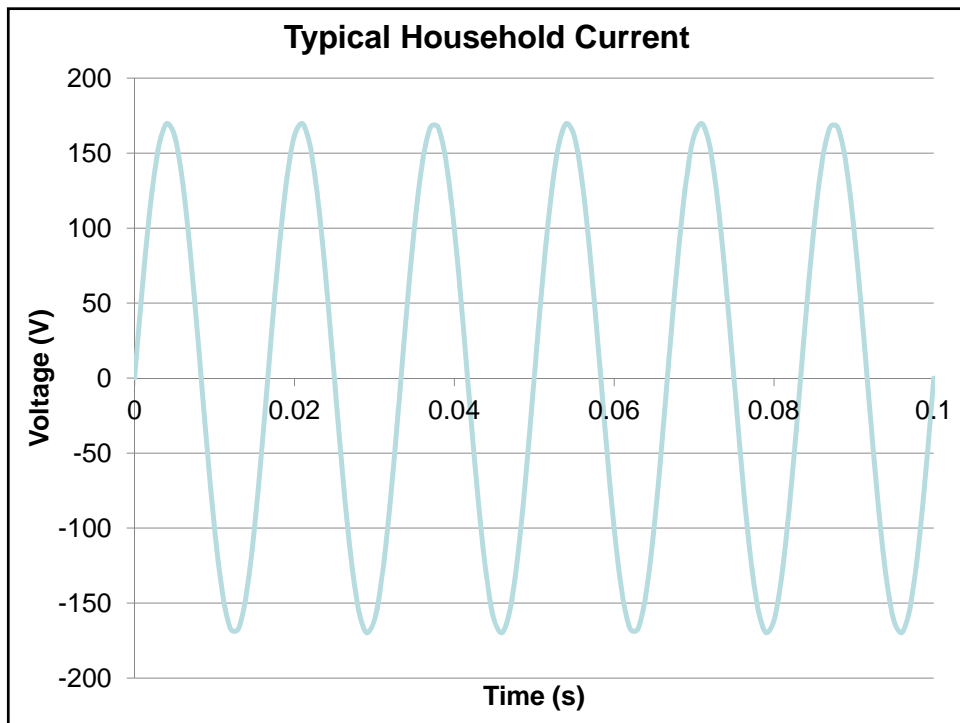
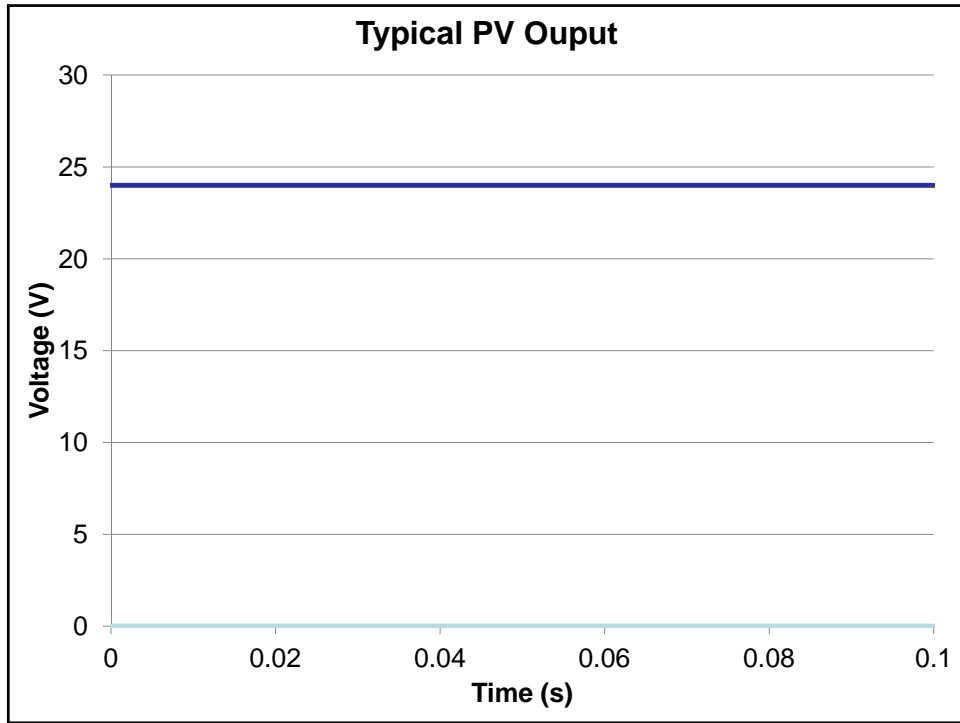

## Inverters

- Link between panels and household power
  - Converts between DC and AC current
    - Panels are DC, Houses are AC
      - DC = significantly more dangerous power
      - Significant transforming and transmission inefficiencies (typical 90-95%... Efficient)
- Provides link to batteries
  - Only necessary when batteries are included

## Stand Alone Systems Vs. Grid-Tied Systems

- Stand Alone
  - System meets all electrical need for building
  - No connection to conventional power grid
  - Goal = Zero Energy
- Grid-Tied
  - System meets some or all of electrical demands
  - Requires connection to power grid
  - Goal = Net Zero Energy

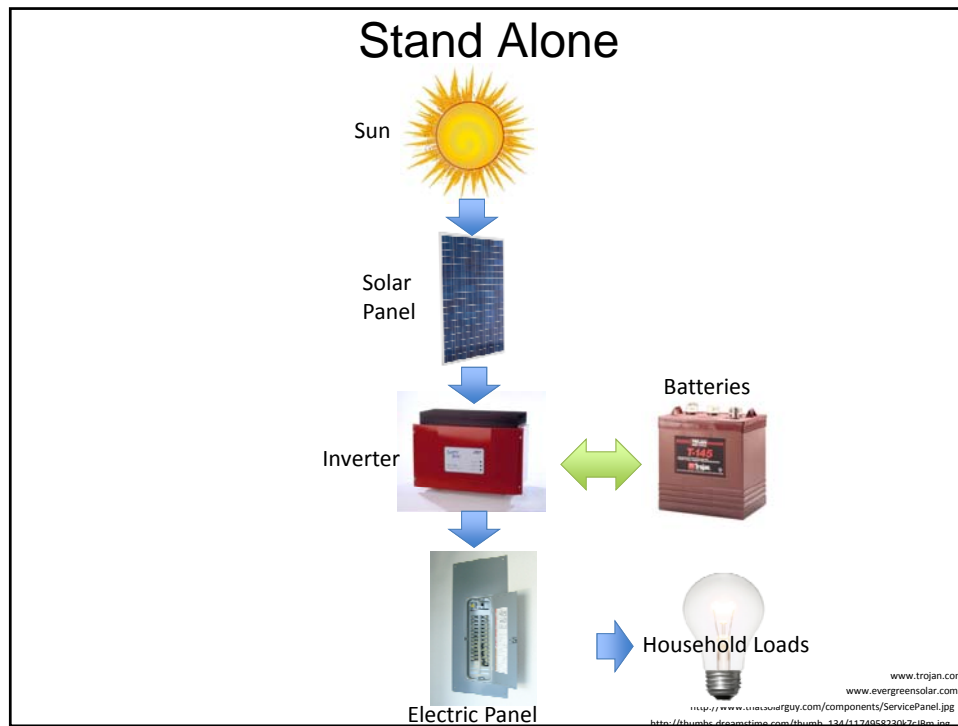

## Stand Alone

- Advantages
  - Works in remote locations
  - No traditional power failures
- Disadvantages
  - Requires much more powerful system
    - Designed for worst case scenario
    - Must produce more power than average consumption
  - Significantly more expensive
  - Greater environmental impact, perhaps even than simply using grid power
  - Could run out of power

[http://newenergyindia.org/Energy%20Payback%20time\\_Opinion%20Page.pdf](http://newenergyindia.org/Energy%20Payback%20time_Opinion%20Page.pdf)

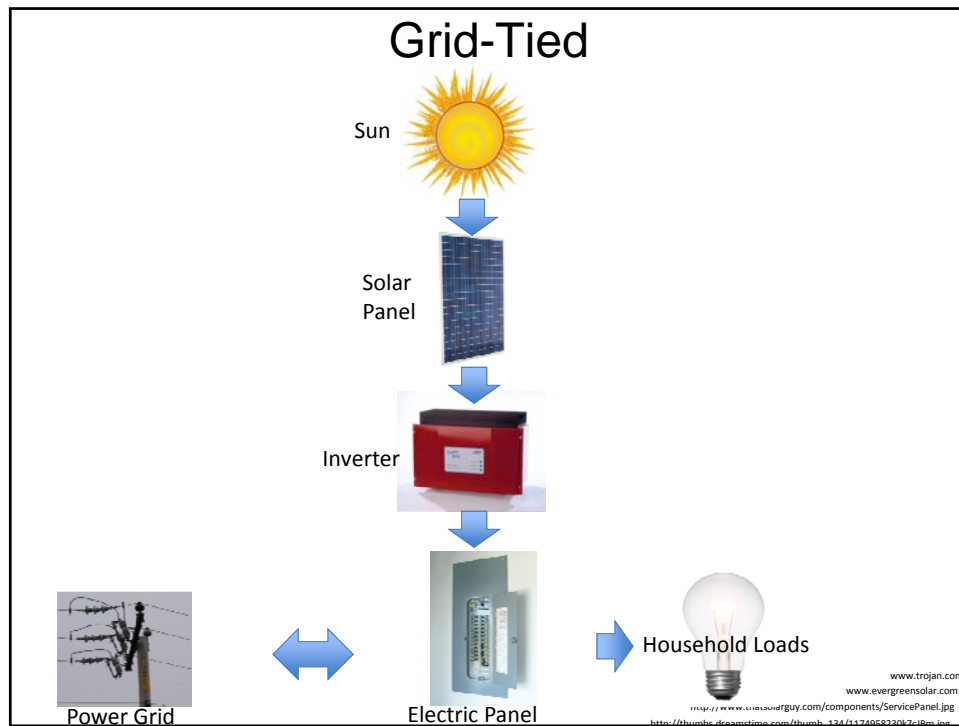

## Grid-Tied

- Advantages
  - System does not have to cover electrical needs at all times
  - Requires less surface area for panels and no batteries
  - Less expensive
- Disadvantages
  - Does not prevent grid power failures
    - Can be dealt with by small battery bank

## When Would You Use Different Systems

- Grid-tied
- Off-grid
- Grid-tied with battery backup

## When Would You Use Different Systems

- Grid-tied
  - Use it anytime possible
- Off-grid
  - When connection to the grid is not possible
- Grid-tied with battery backup
  - Anytime a backup power source is considered critical
  - Should not be used unless backup is required

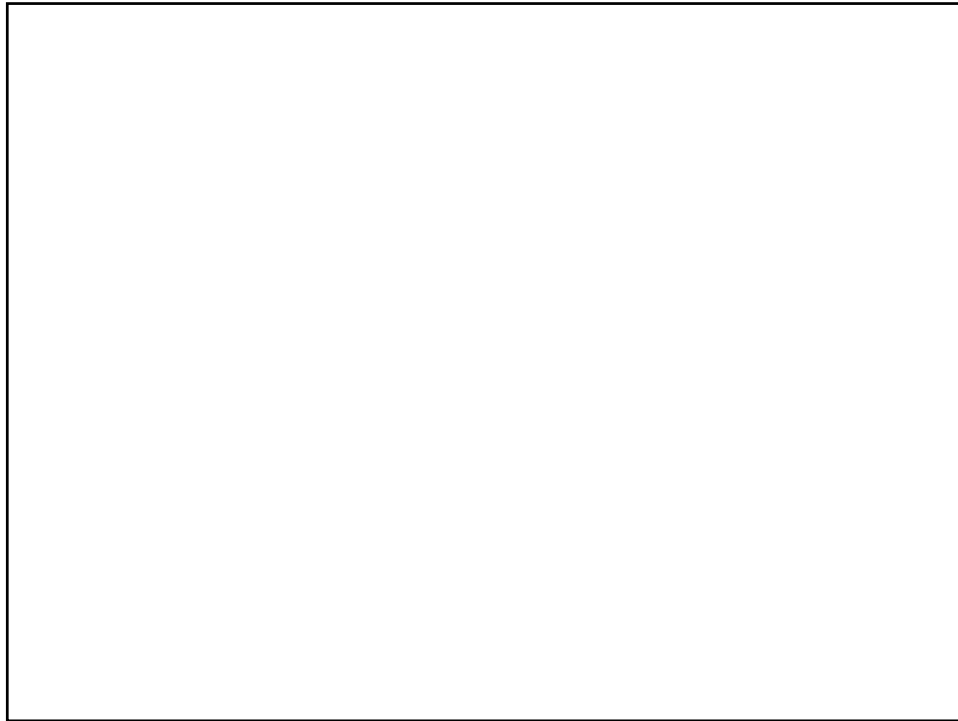

## Sizing a Residential System.

- Energy needs and types:
  - Space heating
  - Domestic hot water
  - Electricity

## Sizing a System

- What is your need, what are your goals?
- How much sun is available?



[www.zeroenergybuilt.com/i/zero-energy.jpg](http://www.zeroenergybuilt.com/i/zero-energy.jpg)

## What is your need?

- Size based on energy bill, BUT...
  - First reduce load
  - Find which appliances are least efficient. Typical consumption values available from Dept of Energy website, but can also use a wattmeter to check devices.
  - Can get from Howe Library!



# How much sun do you get?

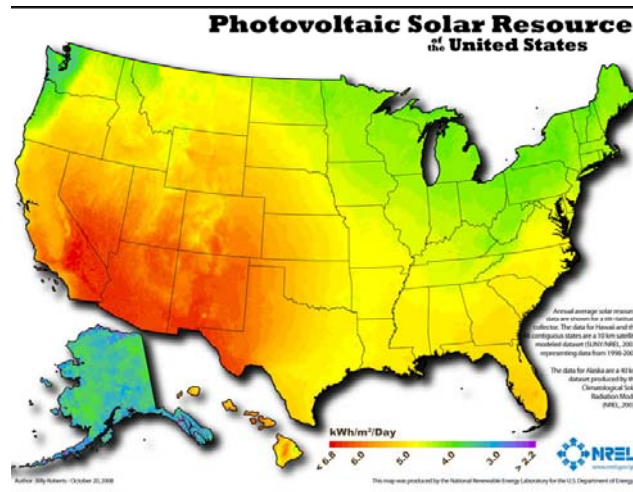

## Solar System Sizing: Grid-Tied

Month	Solar Radiation	Panel Efficiency	Energy Demand for Hanover, NH	Solar System Size
	kwh/m <sup>2</sup> /day	%	kwh/month	m <sup>2</sup>
January	3.8			
February	4.5			
March	4.8			
April	5.1			
May	5.4			
June	5.4			
July	5.5			
August	5.4			
September	4.9			
October	4.0			
November	3.1			
December	2.8			
<b>AVERAGE</b>	4.6		15	620 <b>29.9</b>

•~10'X30' area of panels

## Solar System Sizing: Off-Grid

Month	Solar Radiation	Panel Efficiency	Energy Demand for Hanover, NH	Solar System Size
	kwh/m <sup>2</sup> /day	%	kwh/month	m <sup>2</sup>
January	3.8	15	620	35.0
February	4.5	15	620	32.3
March	4.8	15	620	27.2
April	5.1	15	620	26.5
May	5.4	15	620	24.6
June	5.4	15	620	25.4
July	5.5	15	620	24.6
August	5.4	15	620	24.3
September	4.9	15	620	27.9
October	4.0	15	620	33.2
November	3.1	15	620	44.0
December	2.8	15	620	46.4

- ~10'X50' of panels
- Does not provide enough power for long cloudy periods
- Requires significant energy storage
  - 21KWh per day stored (typically store ~3 days)

## What we will talk about...

- How does PV work
- AC/DC and inverters
- Battery vs. grid
- Sizing a system
- Scalability to the global climate problem

## Global Scalability

- Predicted Global energy use in 2050
  - 610-1040 exajoules/year (exa= $10^{18}$ )
- Theoretical Solar Potential
  - 3,900,000 exajoules/year
- Plenty theoretically, but what limits technical potential?  
You tell me!

## Scalability – Technical Limits

- Conversion Efficiency (a few percent to 20%)
- Land Use (still need to grow crops, have ecosystems)  
(still between 1,575 and 49,837 exajoules, depending on who's estimate you like)

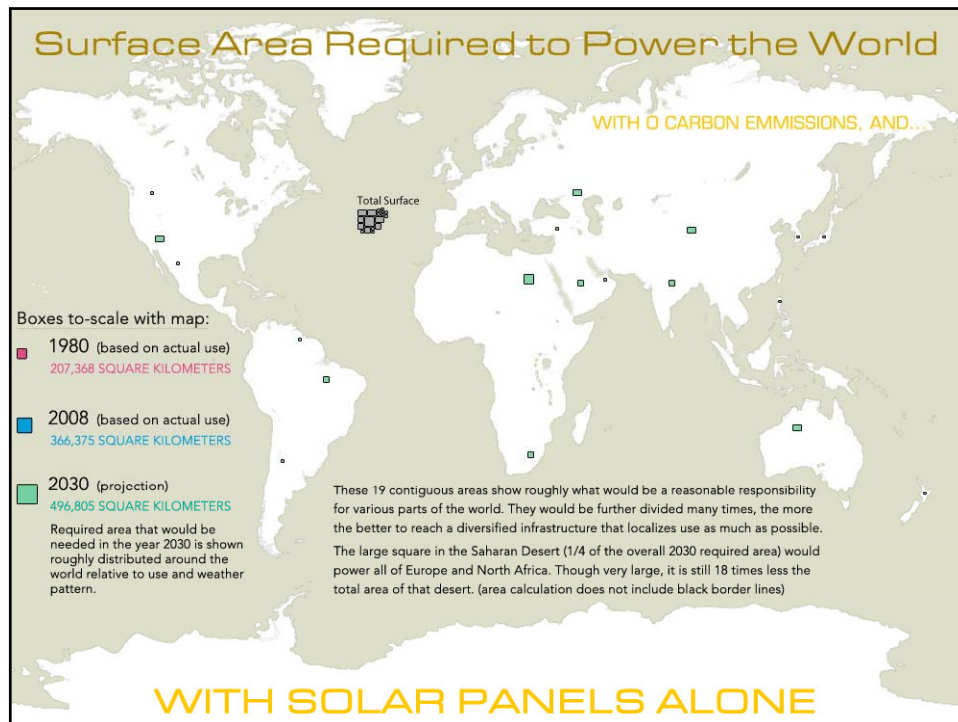

## Scalability – Technical Limits

- Timing.... Oooh. Technical Problem
- Transmission

## Storage

- CST (concentrated solar thermal)
- Heat up pressurized steam or liquid sodium, run through turbine at night



## “Smart Grid”

- Trigger high energy loads at peak production
- Charge electric vehicles



Electric Smart Car

## Complementary or Dispatchable Generation



## Scalability – Economic Limits

- Photovoltaic installations in most parts of the country will not produce a return on investment without government incentive.
- PV is one of the LEAST cost effective ways to reduce carbon emissions.
- What other ways are less costly?

