

Physically-Based Distributed Models for Multi-Layer Ceramic Capacitors

Charles R Sullivan and Yuqin Sun

Thayer School of Engineering
Dartmouth College

<http://power.thayer.dartmouth.edu/>



Introduction

**Why an RLC model
won't do.**

Standard RLC Model for a Cap

- Simple but not accurate
(as much as 5X impedance error).

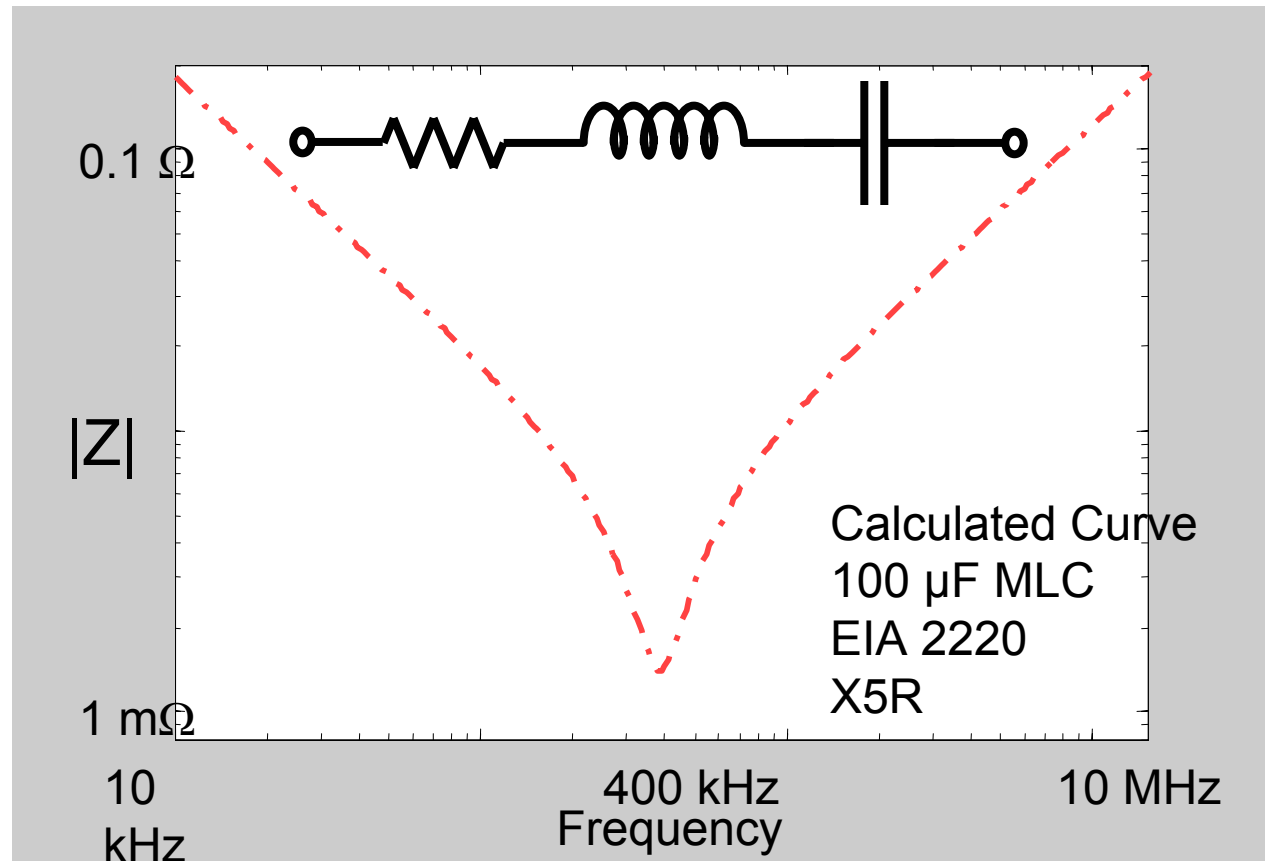

Measurements vs. RLC Model

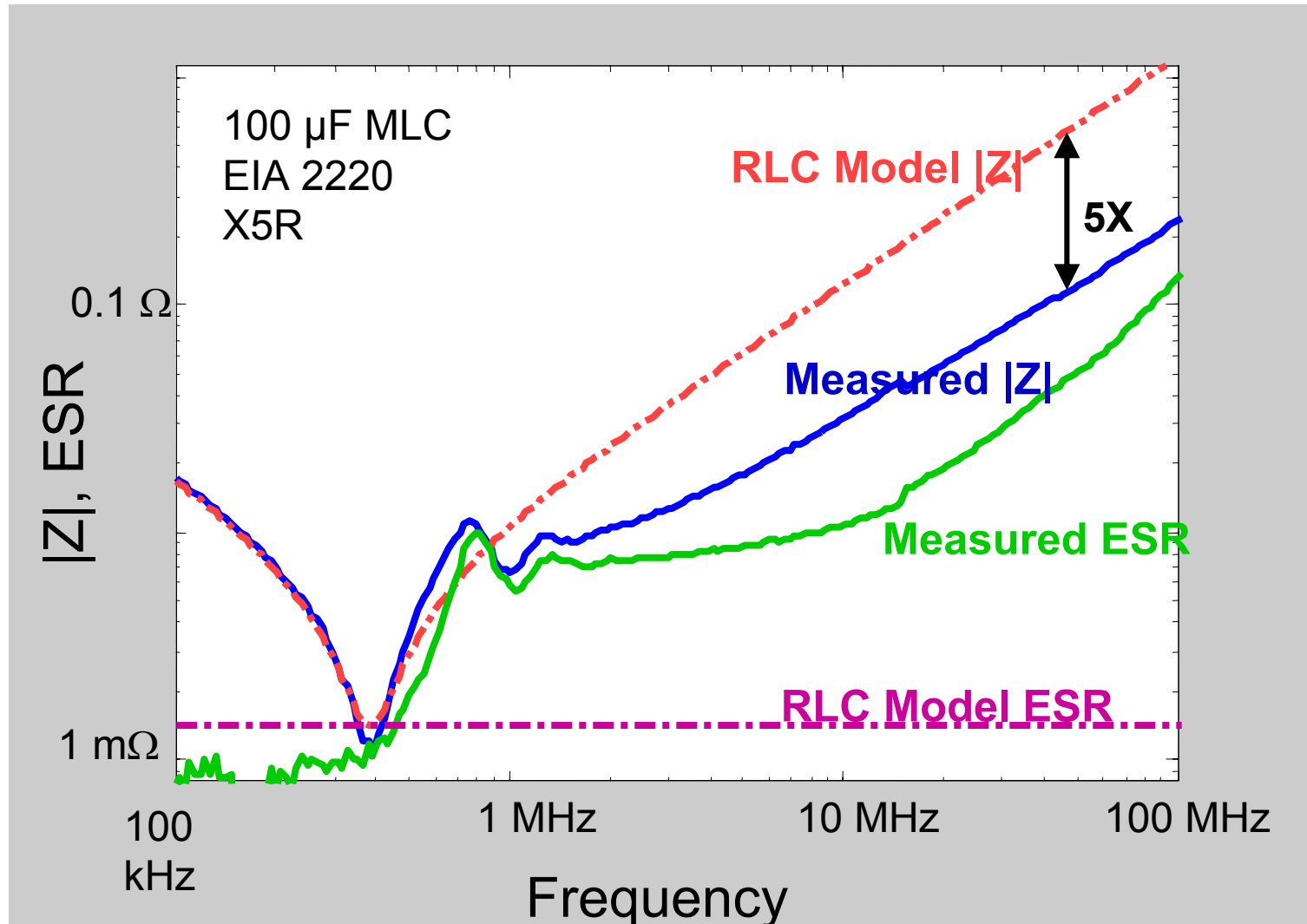

What's Going On?

- Inductance is distributed effect; different for each plate.

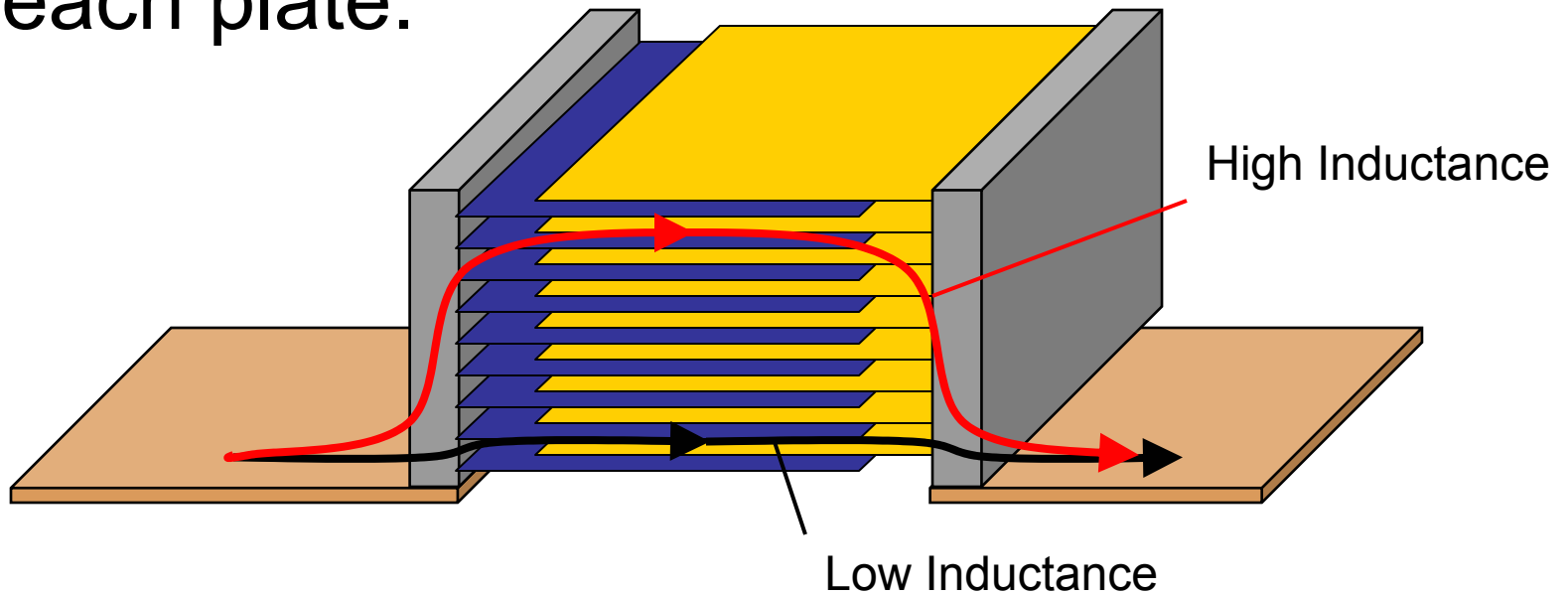

- Behavior is like a transmission line.

Measurements

What to Measure

- Need to be sure measurement technique captures real in-circuit behavior.
- Inductance is only defined for a closed loop.

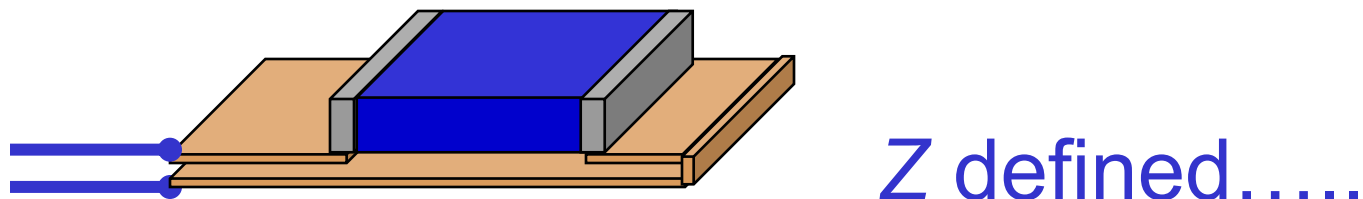
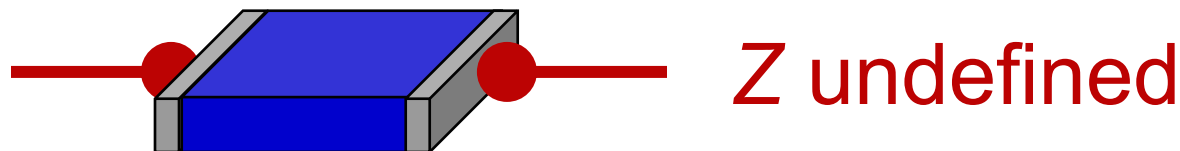

But includes some Z interconnect!

Defining Impedance

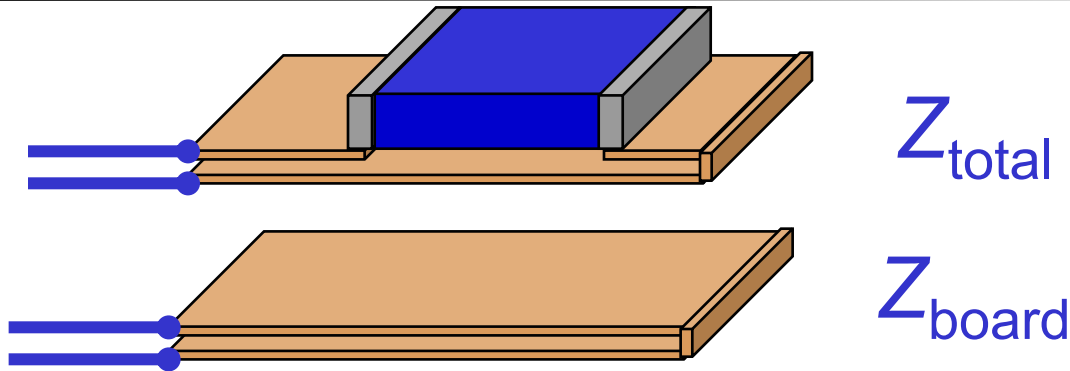

$$Z_{\text{cap}} = Z_{\text{total}} - Z_{\text{board}}$$

- The relevant impedance for application with adjacent ground plane.
- Same inductance as Z_{total} with zero board thickness.
- Can correct for resistance.
- How to measure: pH accuracy test fixture: Session 35, paper 2—here this afternoon.

New Low-Impedance Test Fixture

- Based on Agilent 4TP (four terminal pair) configuration.
- Less than 100 pH stray inductance, ~3 pH repeatability

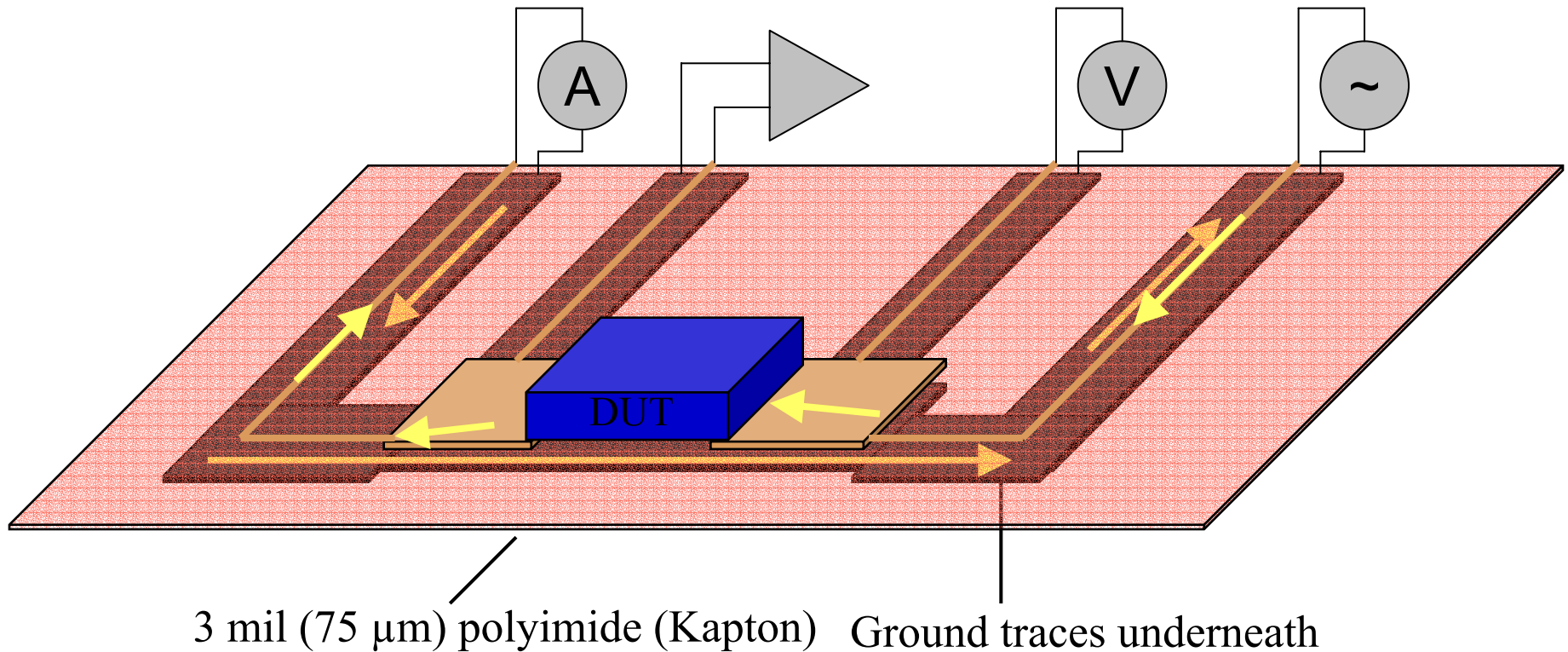

A Better Model

I. Simple Transmission Line Model

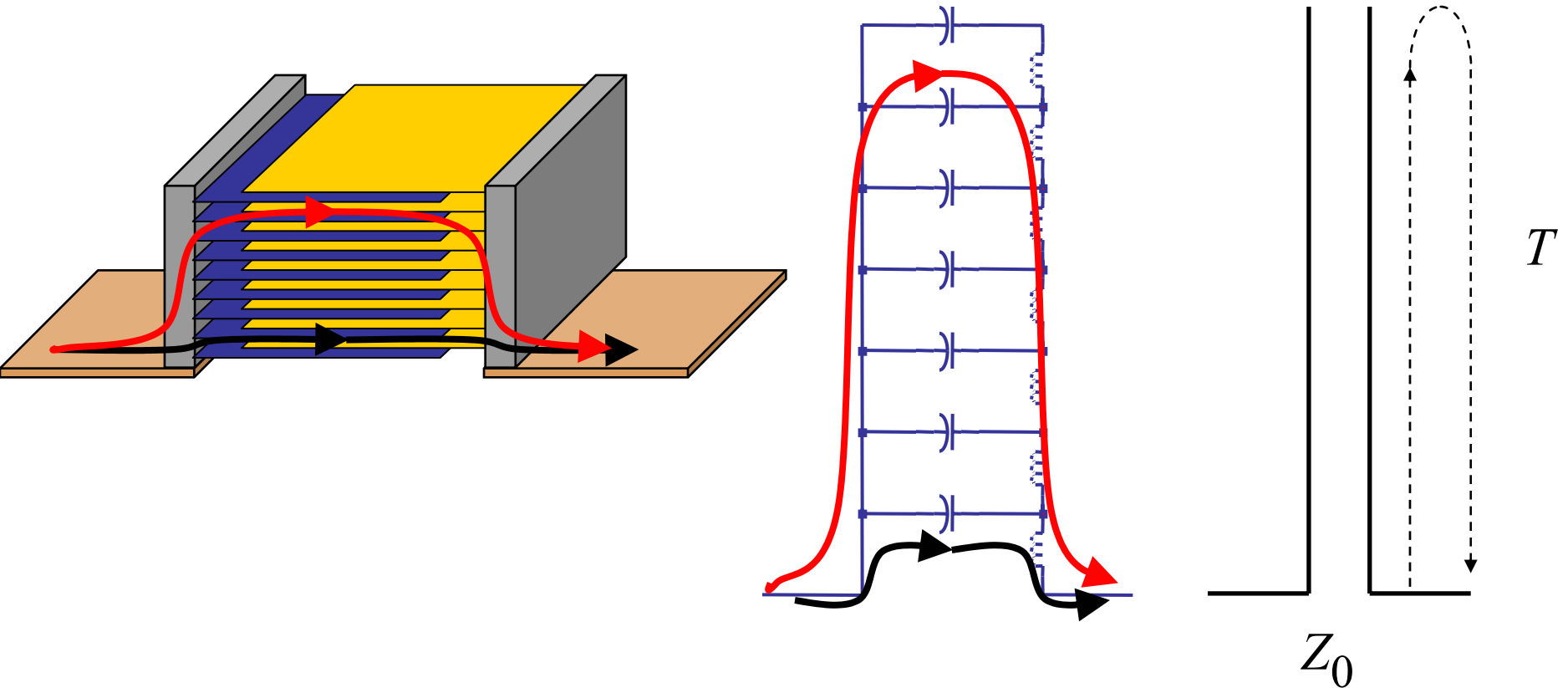

- Actual system: hundreds of plates.
- Model as continuous distributed transmission line.

Two Parameters Describe the Transmission Line Model

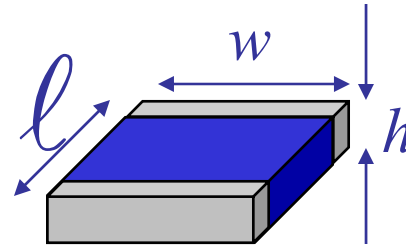

- Parameters linked to geometry.

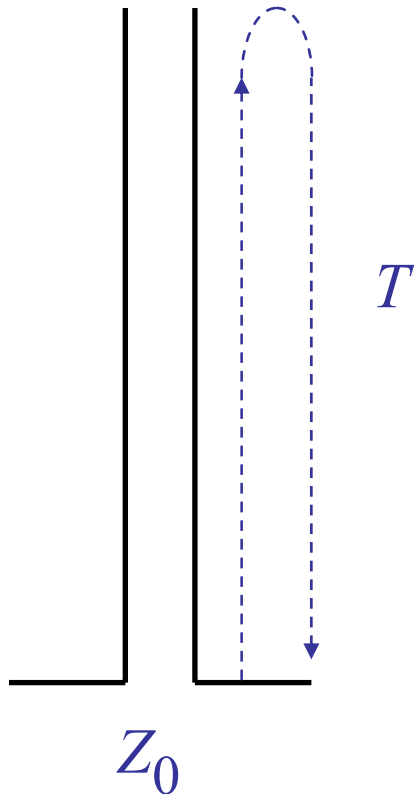

$$Z_0 = \frac{1}{w} \sqrt{\frac{\mu_0}{C_v}}$$

$$T = 2h\ell \sqrt{\mu_0 C_v}$$

where C_v is capacitance per unit volume.

Ideal Transmission-Line Behavior

Calculated from geometry and ESR

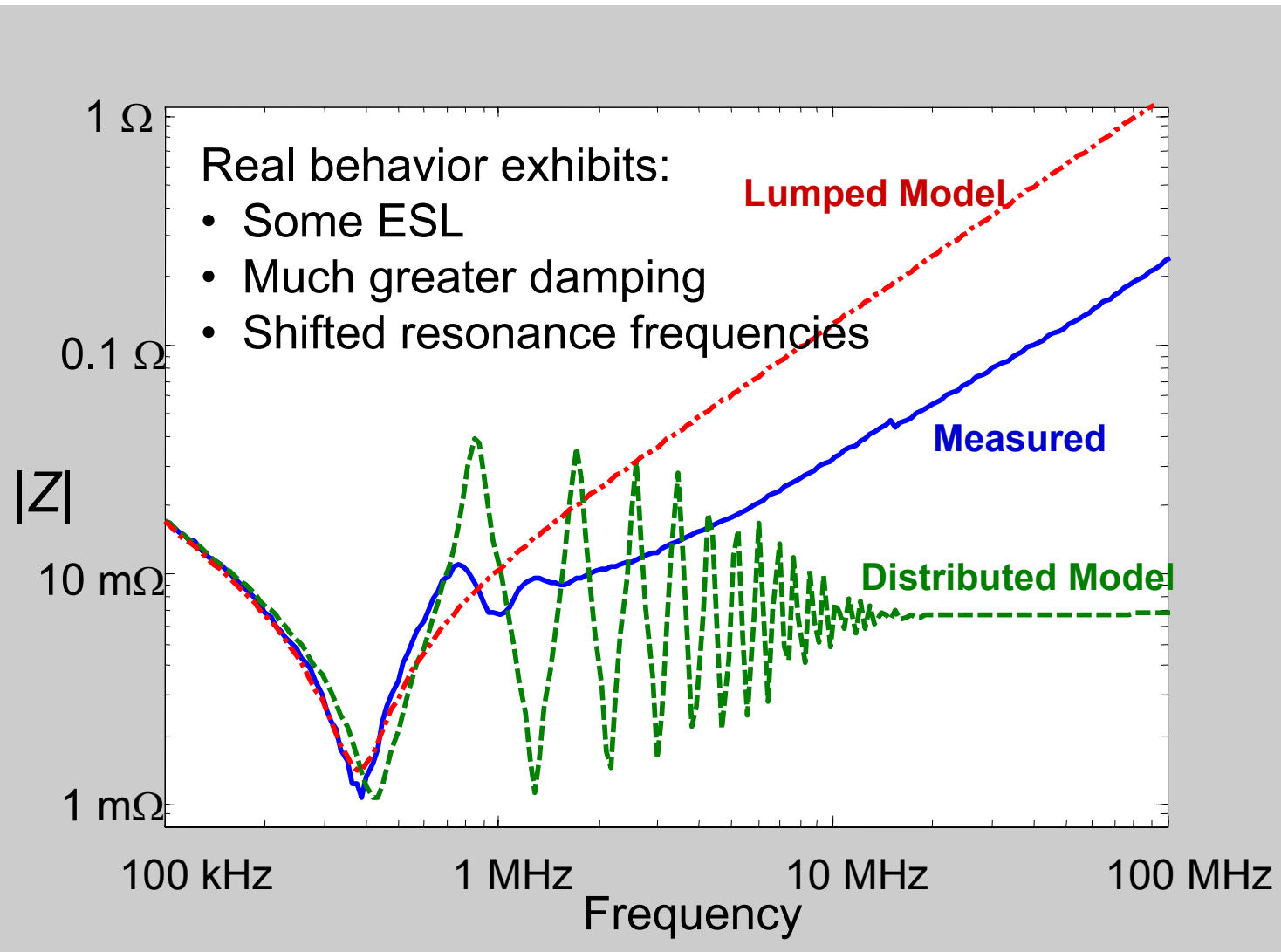

II. Improving the Model

- External L: Models **Coating Effect**

- Damping:

Real damping effects include:

- Series R of plates.

- Eddy-current losses in plates.

Must model both effects

Distributed Model with Added External L

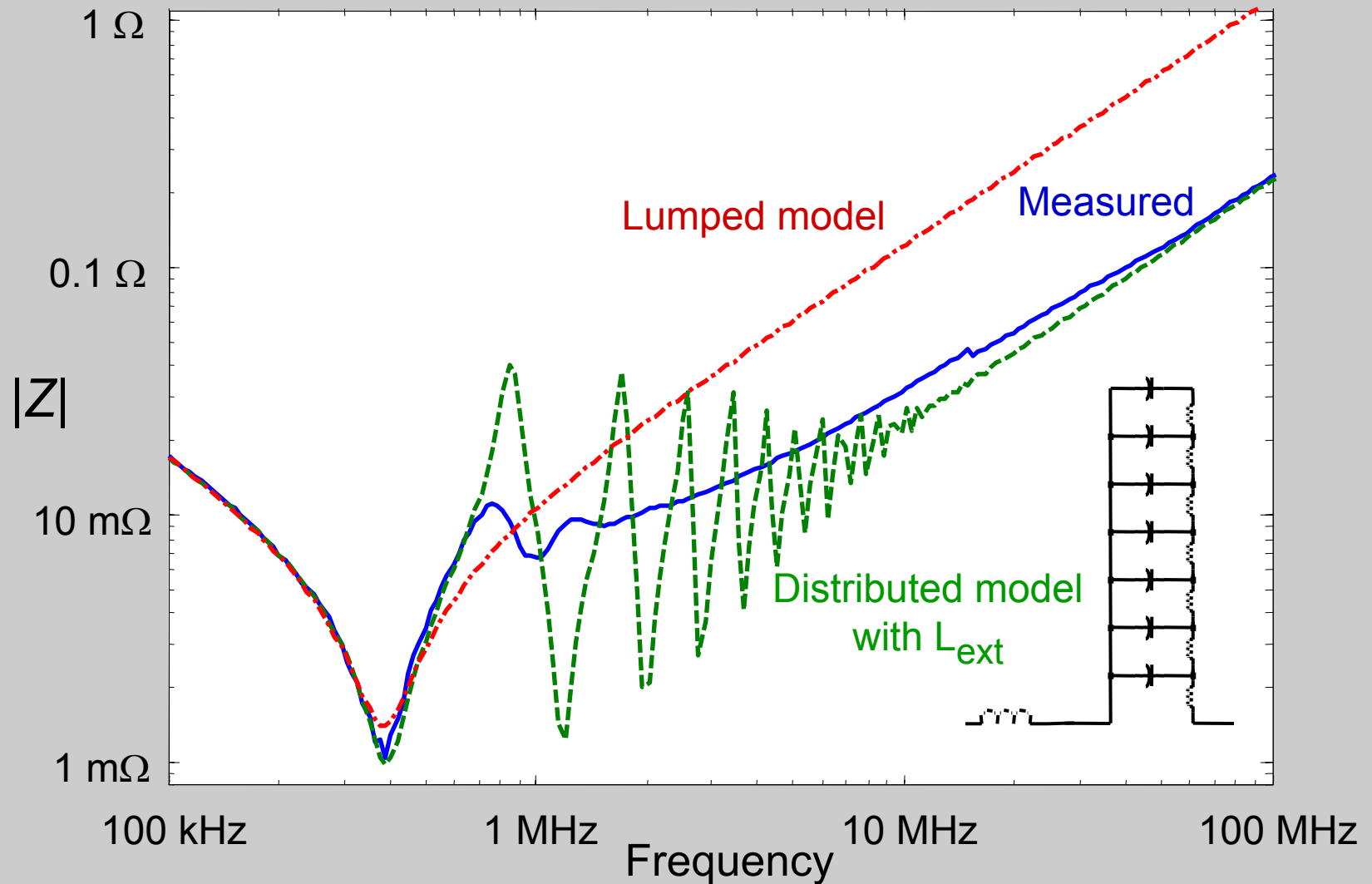

Model with Damping from Series R of Plates

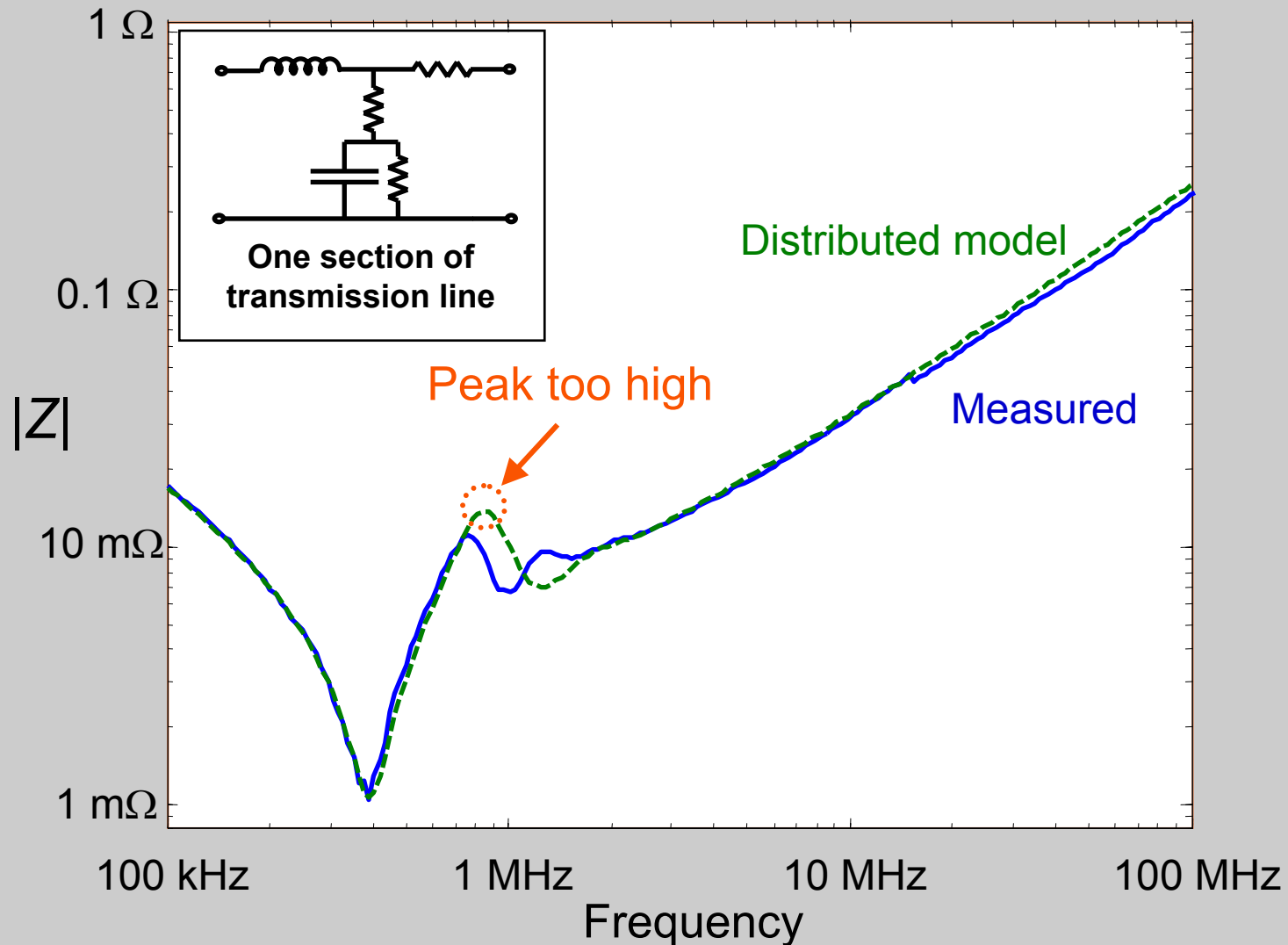

Add Effect of Eddy Currents in Plates

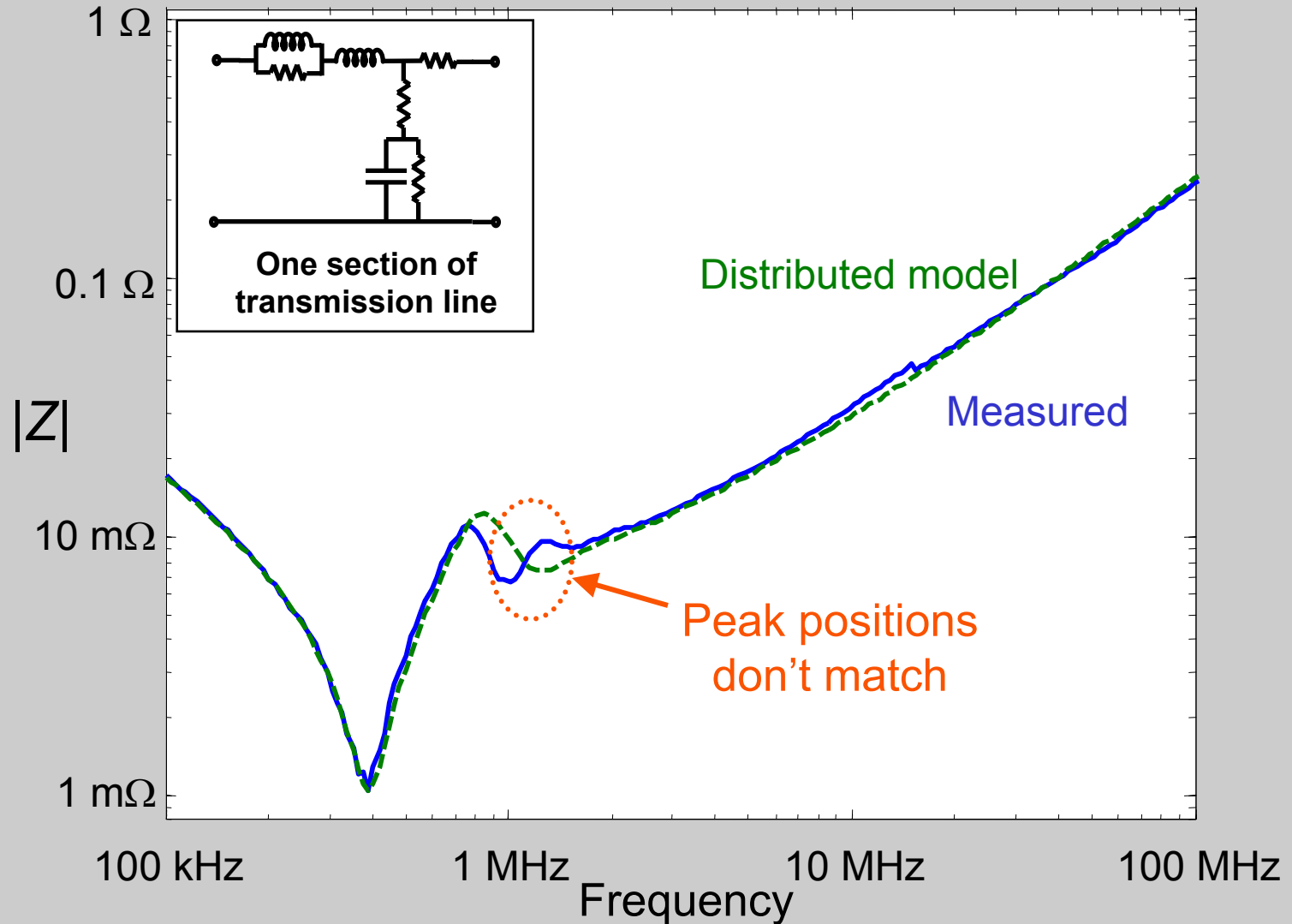

III. Final Model Improvements

- Damping model works OK by including
 - Series R of plates.
 - Eddy-current losses in plates.
- Last remaining discrepancy: non-uniform spacing of resonant peaks.
 - Two possible causes:
 - Non-uniform distributed inductance.
 - Mutual Inductance.

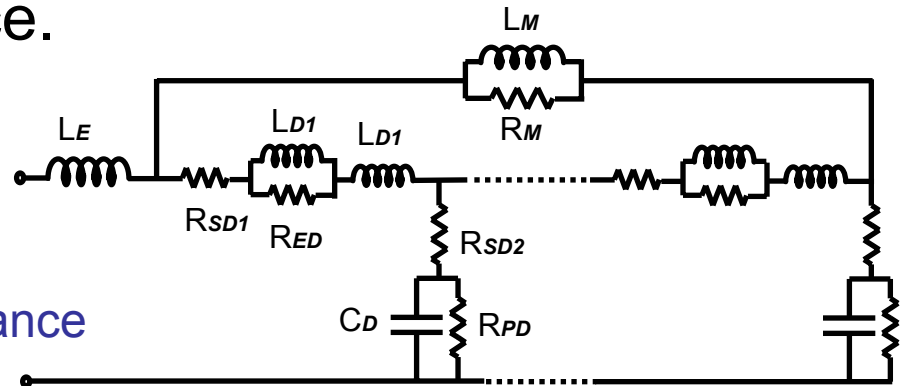

Model including mutual inductance

Model with Both Damping Effects and Non-Uniform Inductance

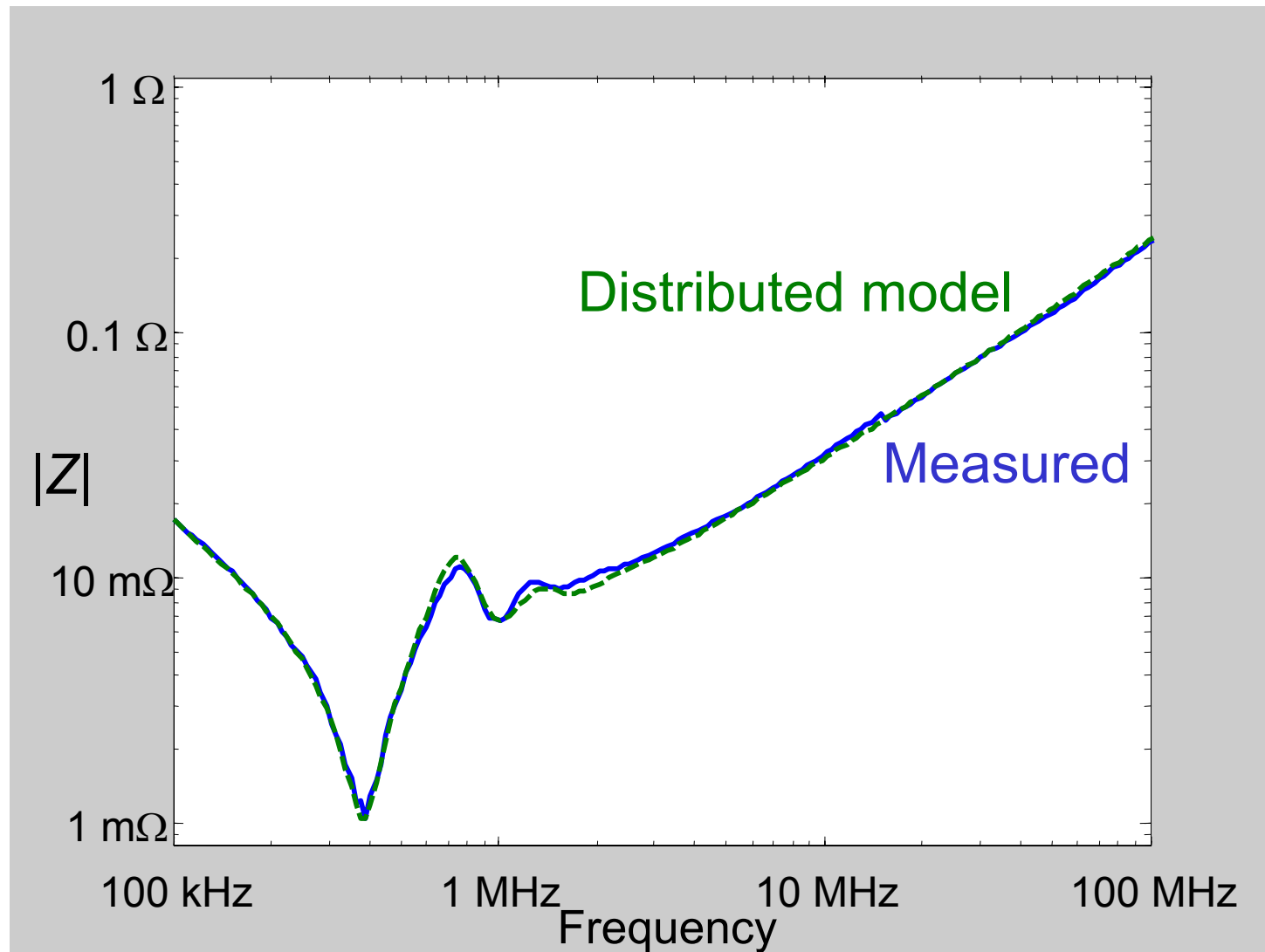

Coating Effect

Why Does Cap Have Extra Series L?

- Thickness of coating

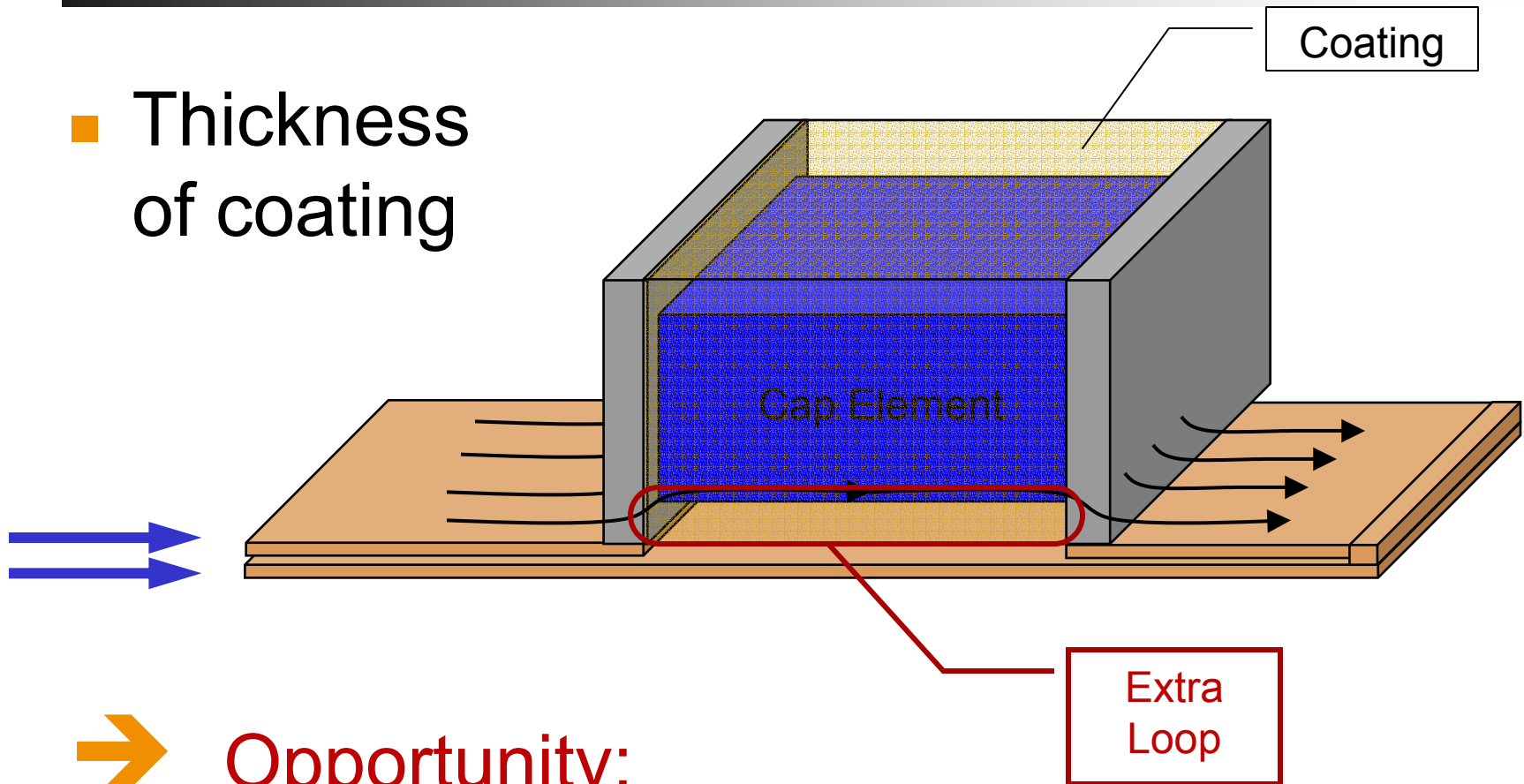

➔ Opportunity:

Reduce coating thickness to reduce external L and HF $|Z|$

Measured Effect of Coating Thickness

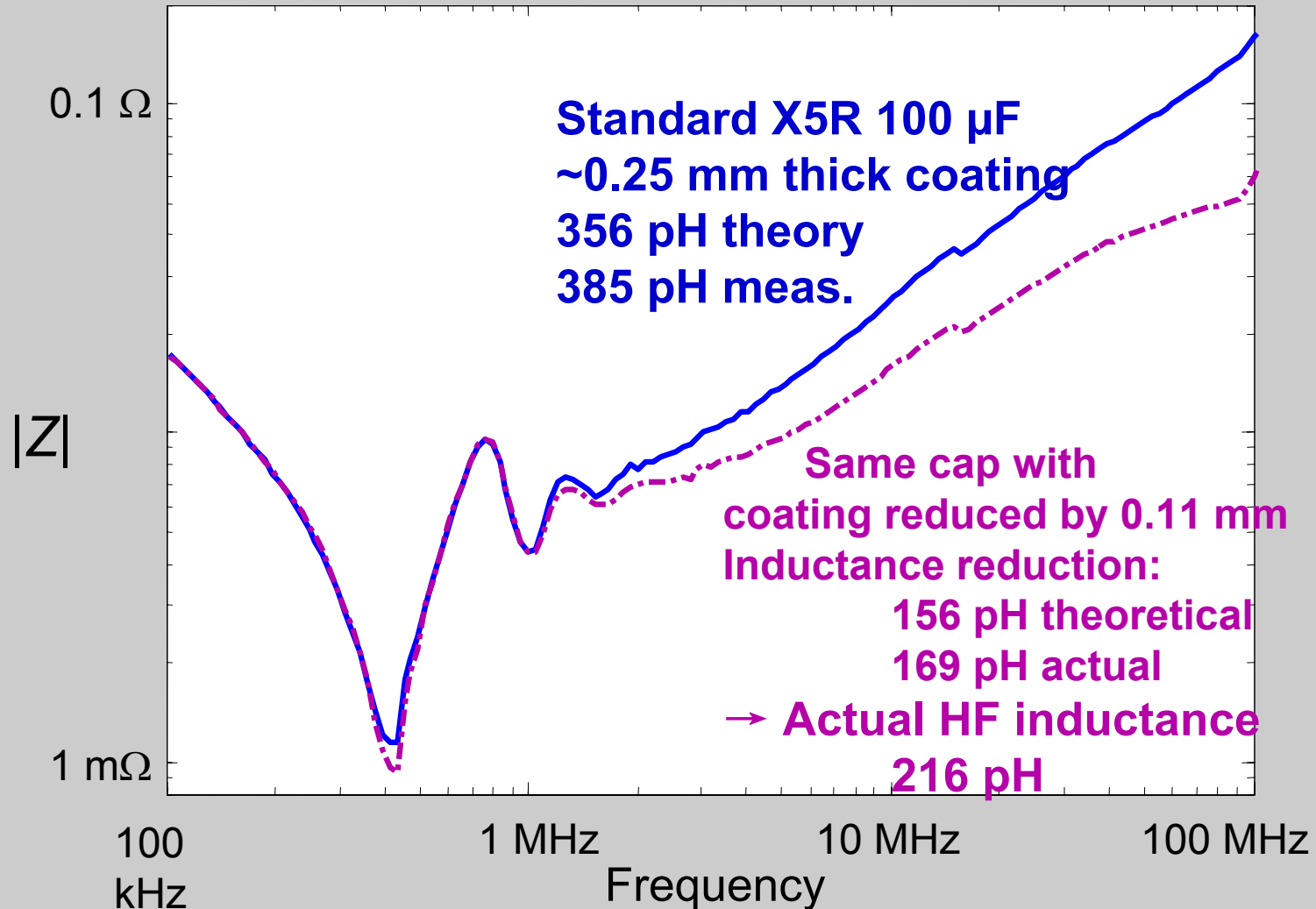

Observations

Simple Frequency Domain Model

- All parameters needed to sketch impedance can be simply calculated

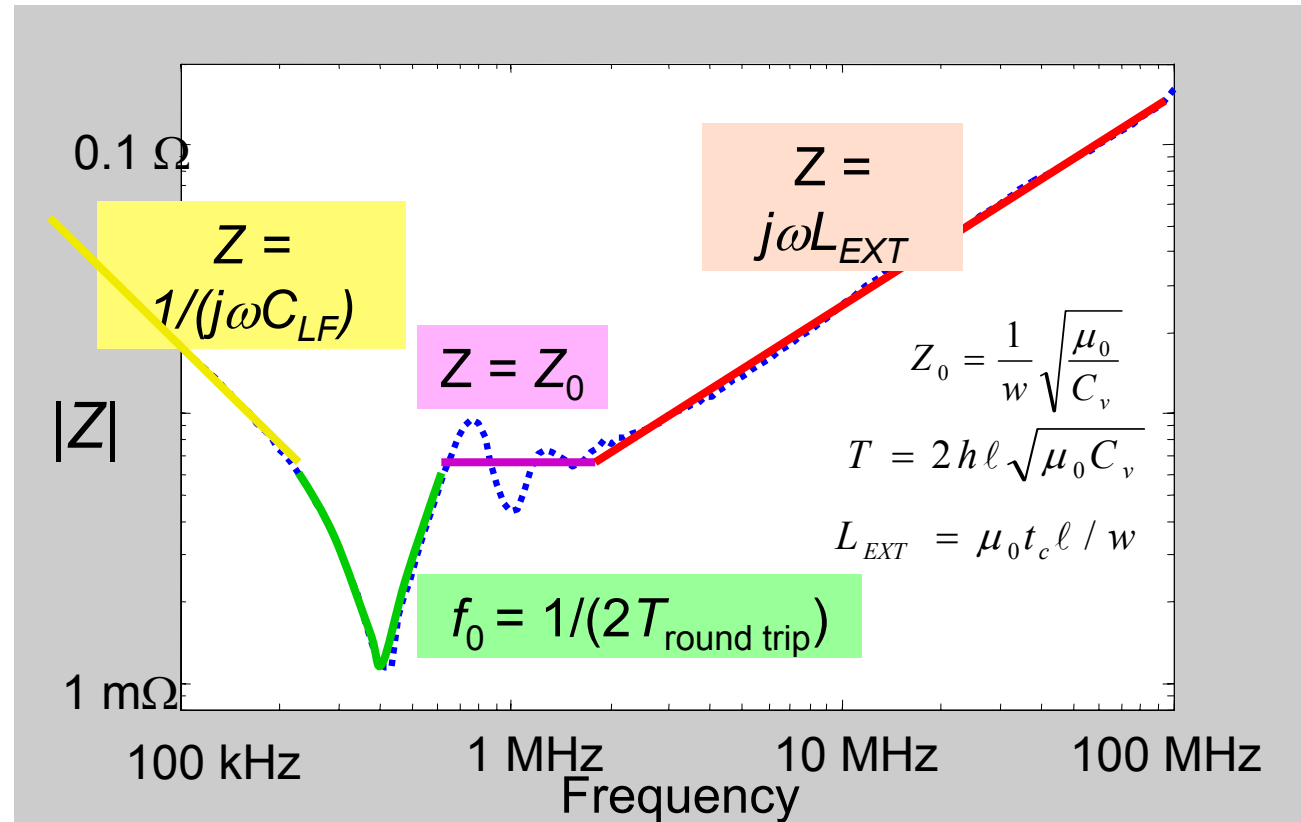

Effect of Plate Orientation

22 μF MLC capacitor—square ends

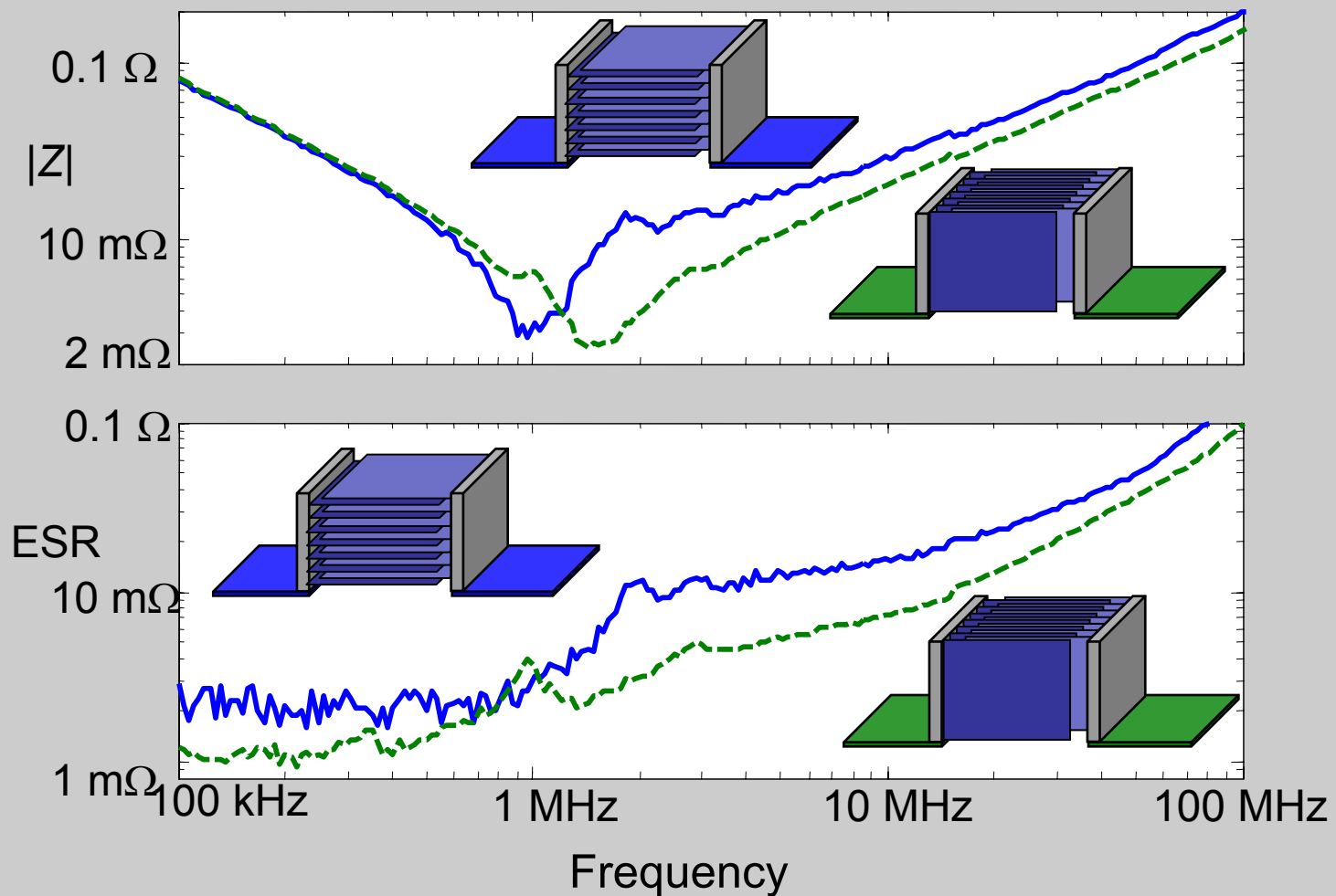

Application

DC-to-DC Converter Output Filter

- PWM waveform and output voltage waveform.

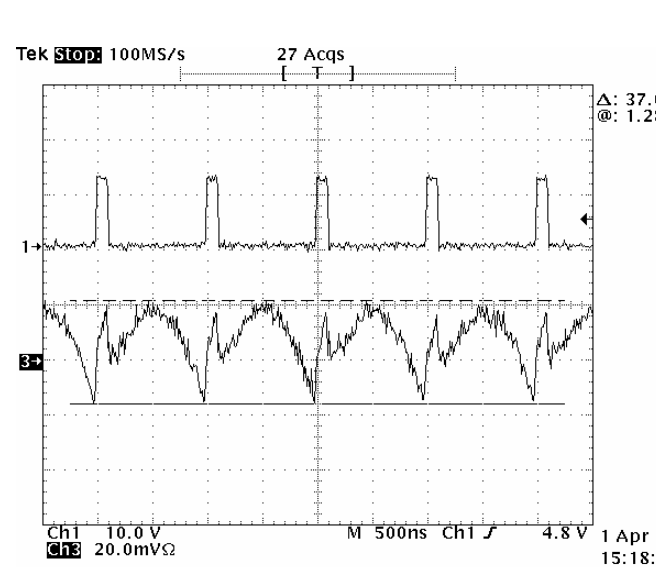

Measured
 $\Delta V = 37.6$ mV

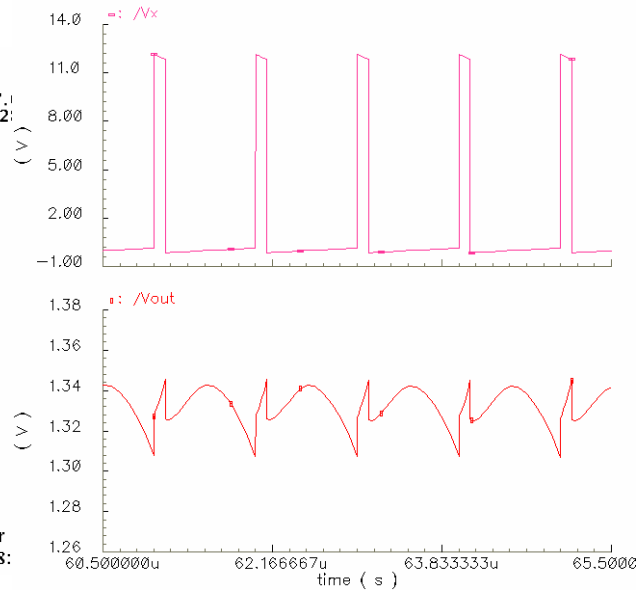

New model
 $\Delta V = 37.7$ mV

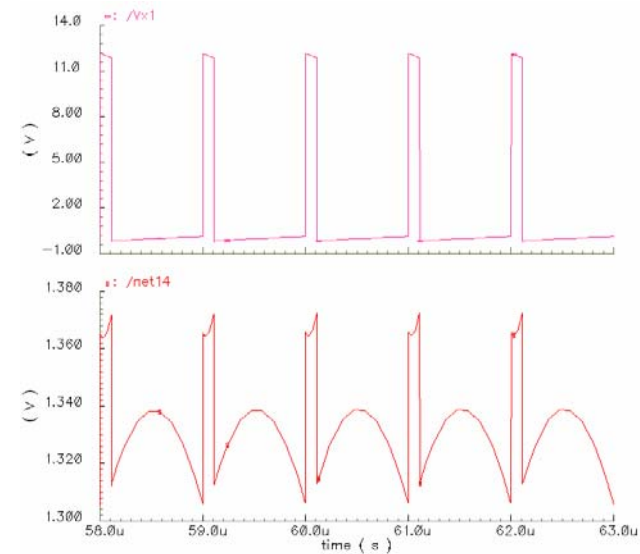

Lumped RLC model
 $\Delta V = 66.4$ mV

- 12 V to 1.2 V, 1 MHz buck converter with 2 x 22 μ F caps
- Distributed model is much better than RLC model.

Conclusions

- MLC capacitors exhibit distributed behavior.
 - LRC model can have factor-of-five error.
 - Improved distributed model can
 - Fit measurements precisely.
 - Match observed in-circuit behavior.
 - Simple model is also useful conceptually.
 - Parameters are easily obtained from geometry.
- High-frequency impedance:
 - Dominated by L_{EXT} , due to coating thickness.
 - Reducing coating thickness can greatly reduce high-frequency impedance.